

Securitron® CEPT

Concealed Electrical Power Transfer

ASSA ABLOY

Installation Instructions

Experience a safer
and more open world

Product Components

Diagram 1 Product Components

- A CEPT Assembly
- B Back Box (x2)
- C Screws, 10-24 x 3/4" Phillips Flat Head Undercut (for metal) (x13)
- D Screws, #10 x 3/4" Phillips Flat Head (for wood) (x13)
- E Dolphin™ Connector (CEPT-10 only) (x17)
- F Wire Nut (CEPT-10 only) (x4)
- G Strain Relief Bushing (x2)

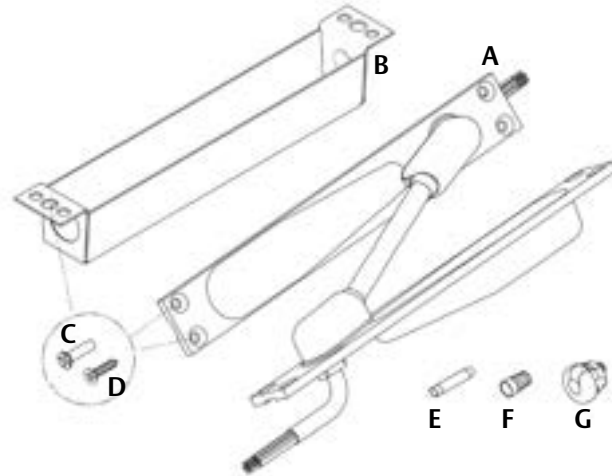

CEPT-TK (Option)

To be used when retrofitting CEPT into an unprepared metal door & frame

Diagram 2 Optional Components

- H CEPT-TK Mounting Brackets (x4)
- I Screws, 8-32 x 1/2" Phillips Flat Head (x10)

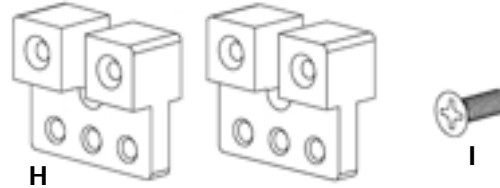

Warranty

The CEPT is covered by the MagnaCare® lifetime replacement no fault warranty. No registration is required. Product will be replaced forever, for any reason, including but not limited to installation error, vandalism, or act of God. Replacement product is shipped at ASSA ABLOY's expense next day air if needed.

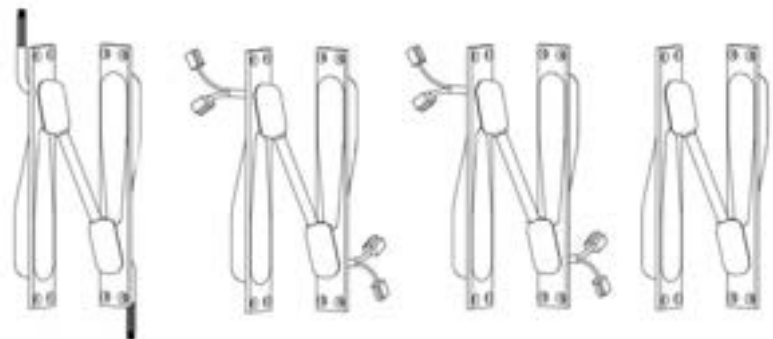

CEPT-10
Traditional, Connect
10 Wire (2 + 8)
(2) Wire Nut +
(8) Crimp

EL-CEPT
Electrolynx®
(ASSA ABLOY)
12 Wire
Connectors:
8pin + 4 pin

CEPT-C5E
CAT 5e
(TIA/EIA-568-B
compatible) 9
Wire (8 + 1)
Connectors:
6 Pin + 4 Pin

CEPT-NW
No Wires
Furnished

Specifications

Physical

For proper installation and operation of the CEPT, the thickness of the door should be 1-3/4" minimum. The door opening limitations listed here apply to a 1-3/4" door equipped with the following hinge sizes and configurations.

Door Swing Limitations

DOOR HINGE CONFIGURATION	DOOR OPENING ANGLE RANGE
4-1/2" to 5" Butt Hinge	0-180°
5-1/2" Butt Hinge	0-130°
6" Butt Hinge	0-110°
3/4" Offset Pivot	0-110°

Electrical (the following chart shows the electrical specifications for each CEPT model)

MODEL	TYPE	WIRE SIZE/QTY	CURRENT LIMIT (PER WIRE)
CEPT-10	10 Wires	18 AWG / 2	Max. 5A
		22 AWG / 8	Max. 1A
EL-CEPT	ElectroLynx®	22 AWG / 12	Max. 1A
CEPT-C5E	CAT 5e	24 AWG / 8	Max. 1A
		22 AWG / 1	Ground (Max. 1A)
CEPT-NW	No Wires Furnished	(see note below)	Max. 1A

NOTE: For the CEPT-NW, given the movement of the electrical power transfer during door movement, it is required that certain steps are taken to prevent wire breakage of 'installer provided' cabling.

1) Use only highly flexible cable with a robust flexible jacket. Flexible cabling is characterized by a high copper strand count (we recommend at least 19 strands) while a robust flexible jacket is at least 1/32" thick (with a maximum jacket OD of 0.275") made of PVC, PTFE, polyolefin or similar jacket material.

2) Provide for some wire slack for the wire entering and exiting the CEPT. The wire bundle must be free to move (approximately 1") within the CEPT during normal door movement to prevent wire breakage. As such, any splices or connectors should be at least 2" away from the exit of the power transfer device to ensure the wire is not restricted from moving within the CEPT during normal door movement. Although using the above recommendations reduces the risk of wire breakage, ASSA ABLOY cannot be held responsible for wire failure in power transfer devices in which ASSA ABLOY did not provide the wiring.

Prepare the Door & Frame for CEPT

If the door and frame have not been modified by the factory to accept the CEPT, then prepare the door and frame as shown in **Diagram 3**. For metal door and frame installations, the CEPT-TK option will need to be installed, see **Diagram 4**.

Diagram 3 CEPT

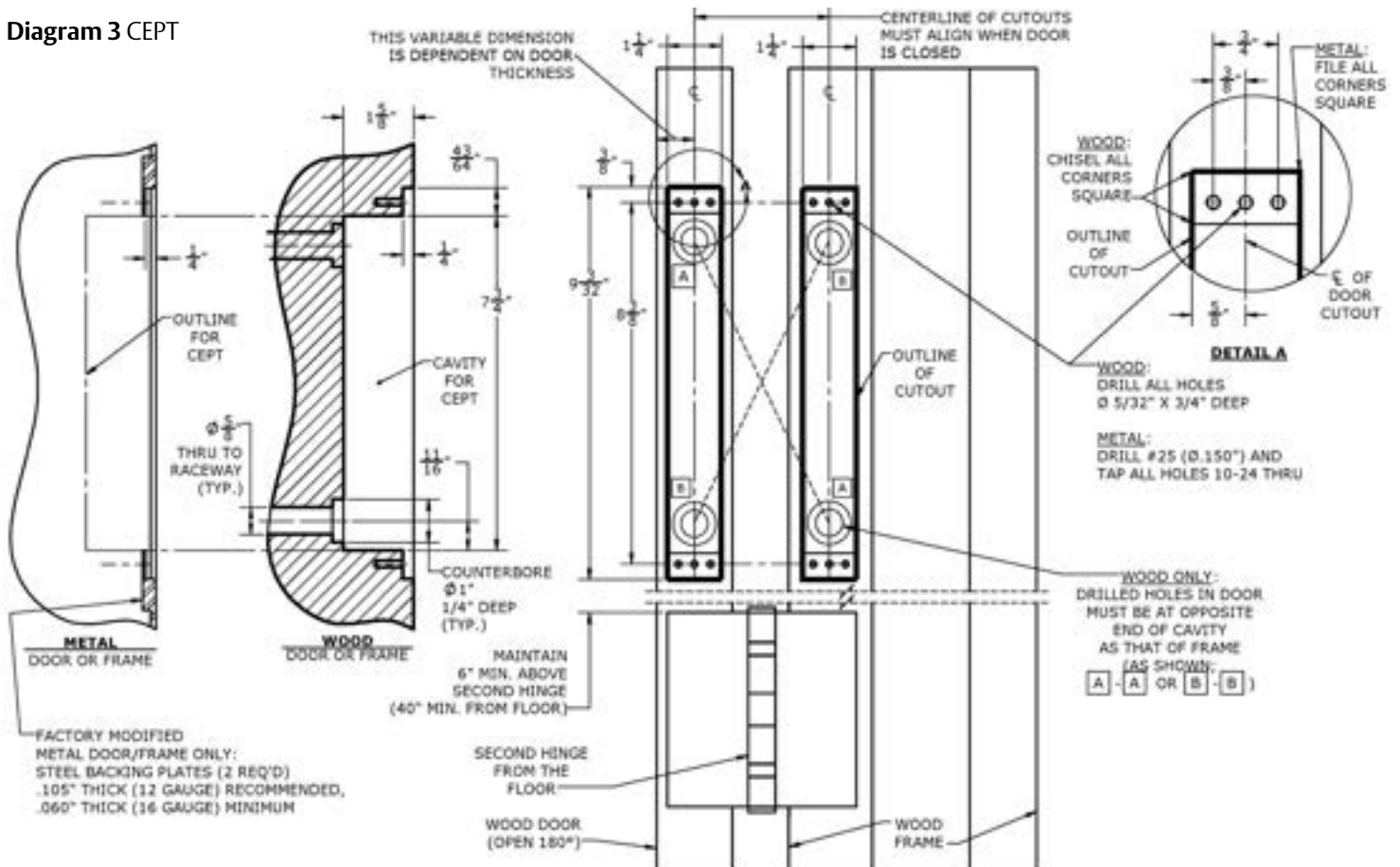

Prepare the Door & Frame for CEPT-TK

For metal door and frame installations, the CEPT-TK option will need to be installed

Diagram 4 CEPT-TK

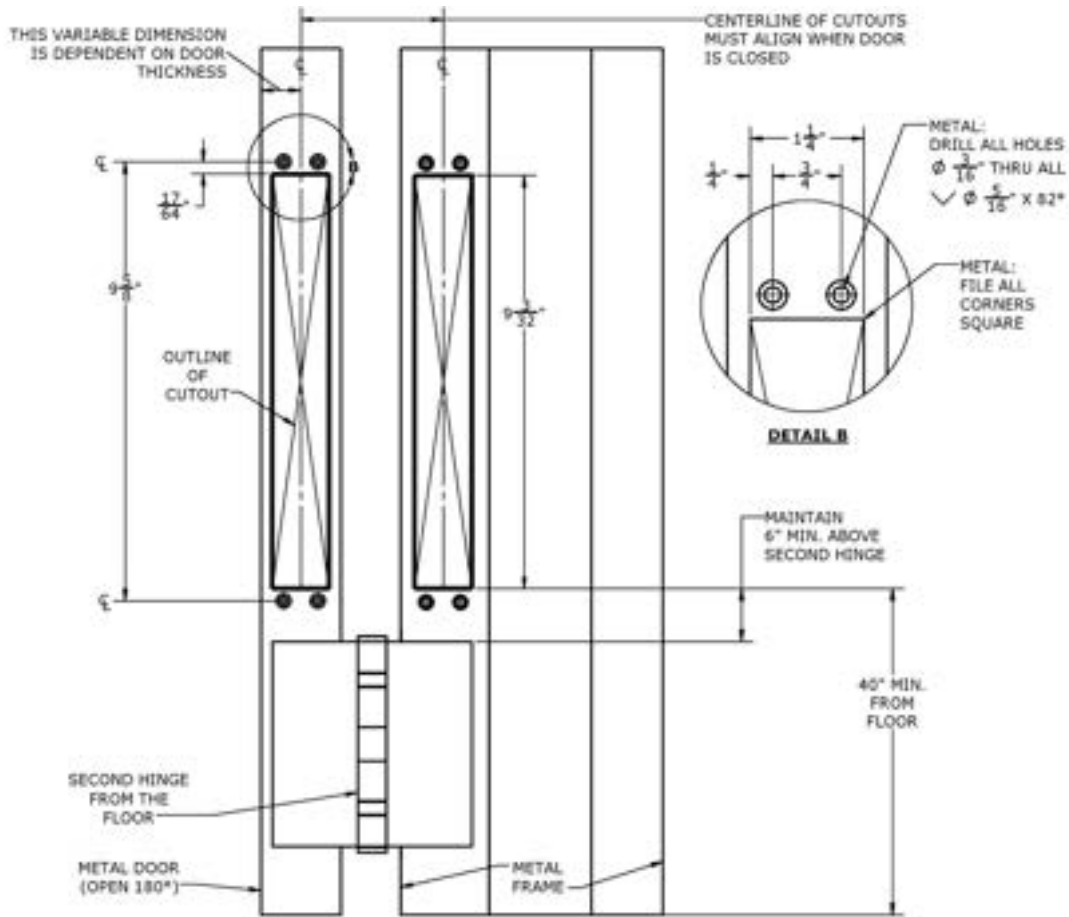

CEPT-TK Installation

For steel (or aluminum) construction without backing plates.

- 1 Orient the LETTER on the bracket facing out, see **Diagram 5**.

NOTE: "S" is for steel door & frame construction
"A" is for aluminum door & frame construction

- 2 INSERT Bracket inside of the cutout
- 3 SECURE with 8-32 x 1/2" screws

Diagram 5
Install the CEPT-TK mounting brackets

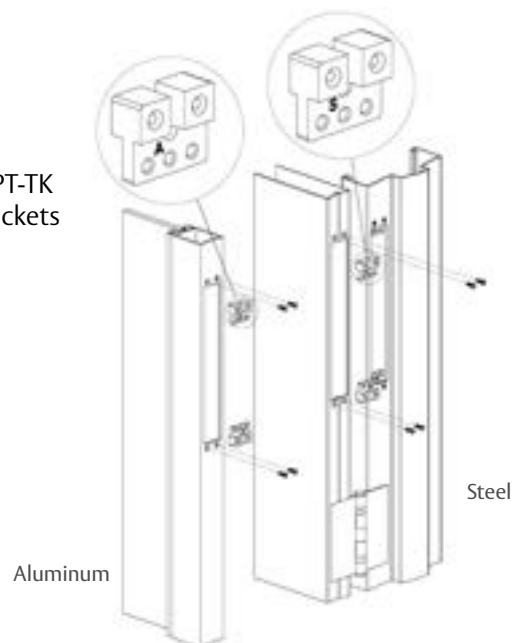

Installation

- 1** ROUTE CABLE through the holes in the door and the frame.
- 2** REMOVE KNOCK-OUTS from the back box
NOTE: 7/8" diameter knock-outs for Electrical Metallic Tubing (EMT) 5/8" diameter knock-outs for Strain Relief Bushing.
- 3** ROUTE CABLE thru 5/8" diameter knock-out.
- 4** INSTALL the strain relief bushing, see **Diagram 6**:
NOTE: ALLOW sufficient wire length (loop) for making connections
- 5** ATTACH BACK BOX with (1) screw thru the center hole
- 6** ATTACH CEPT with (2) screws thru outer holes
NOTE: Use 10-24 X 3/4 screws for METAL.
Use #10 X 3/4 for WOOD see **Diagram 7**.
- 7** Make Wiring Connections
 - **CEPT 10 model:** terminate the wire nuts for the two-18 AWG wires, and the Dolphin™ connectors (crimp type) for the eight-22 AWG wires.
 - **EL-CEPT model:** terminate the ElectroLynx® connectors
 - **CEPT-C5E model:** terminate the CAT 5e connectors

Diagram 6 Install the strain relief bushing

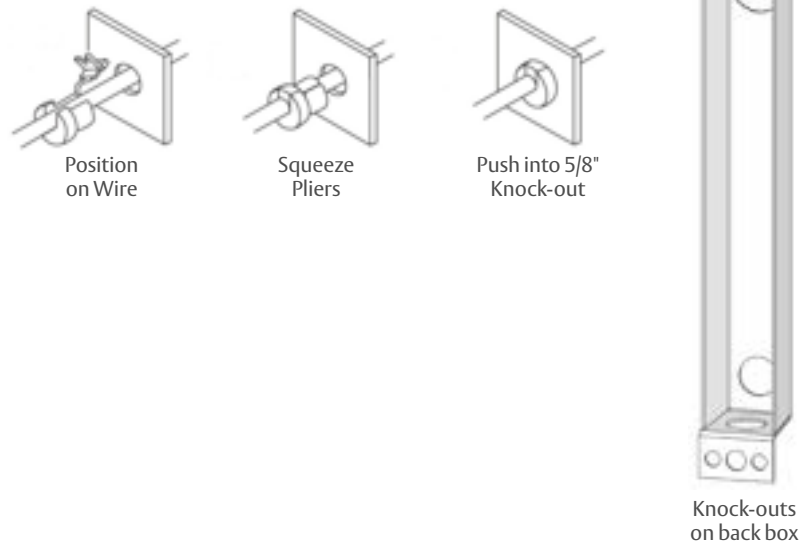

Diagram 7 Attach back box and CEPT

