

# AQL Series Intelligent Power Systems

Installation Instructions

**SECURITRON**  
**ASSA ABLOY**

Experience a safer  
and more open world

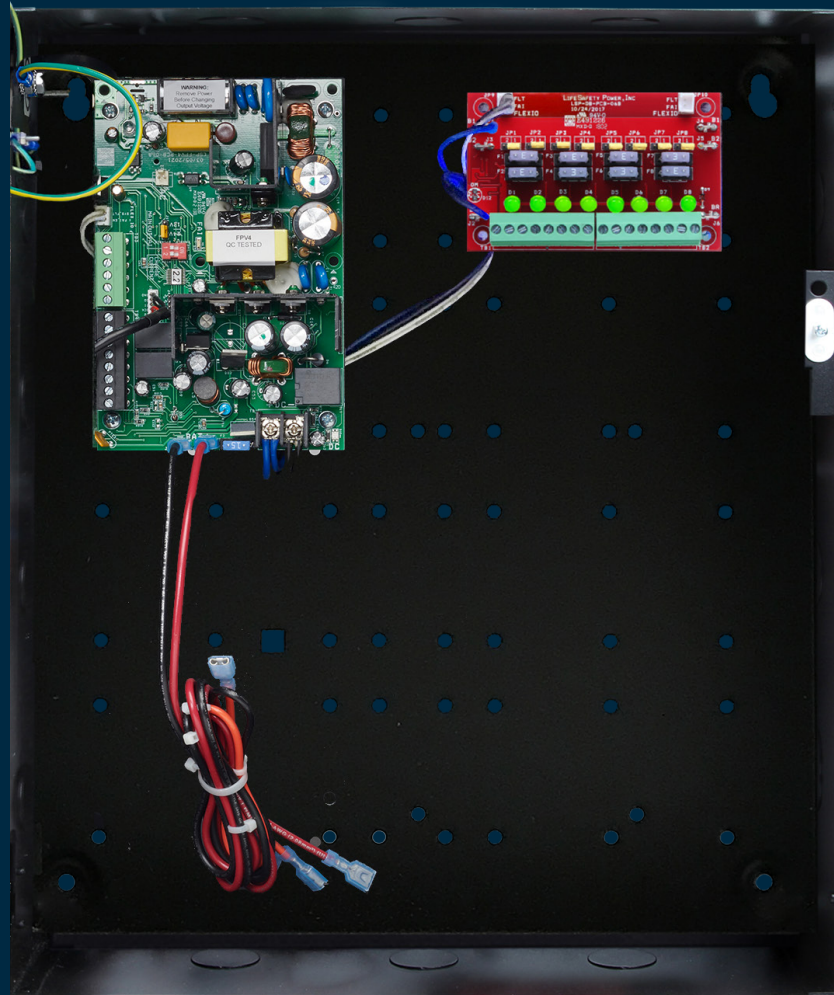

## Product Pages



AQL4, AQL6, AQL102/AQL104 Power Supply Boards.....	4
D8/D8P Power Distribution Module .....	10
R8 Power Relay Module .....	11
B100 Secondary Voltage Module .....	13











# Introduction

## Symbol Definitions

The following symbols are used throughout this manual:

	<b>Shock Hazards</b> within the enclosure. Service should only be performed by qualified service personnel.
	<b>Important Information</b> intended to help the installer avoid personal injury or property damage.

## Warnings

	Installation and service should be performed only by qualified service personnel and should conform to all local codes.
	To reduce the risk of electric shock or fire, do not expose this equipment to rain or moisture.
	Replace fuses only with the same type and rating as indicated in the specifications section of this manual.
	This equipment shall be installed in a manner which prevents unintentional operation by employees, cleaning personnel, or others working in the premises, by falling objects, customers, building vibration, or similar causes.
	This equipment is not intended for use within the patient care areas of a Health Care Facility.
	To prevent impaired operation, ensure that all wiring is routed and secured to prevent accidental open or short circuit conditions.
	The system and any batteries (if used) should be tested at least once per year to ensure proper operation.
	Batteries (if used) should be maintained at an ambient temperature of between 32° and 120° degrees Fahrenheit (0°–49° Celsius) or premature loss of battery power could occur.
	Test and verify output voltage before connecting the load.

## FCC Information

This equipment has been tested and found to comply with the limits for a Class A digital device, pursuant to Part 15 of the FCC Rules and ICES-003. These limits are designed to provide reasonable protection against harmful interference when the equipment is operated in a commercial environment. This equipment generates, uses, and can radiate radio frequency energy and, if not installed and used in accordance with the instruction manual, may cause harmful interference to radio communications. Operation of this equipment in a residential area is likely to cause harmful interference in which case the user will be required to correct the interference at his own expense.

## Conventions Used Within this Manual

Positional information (e.g. top, bottom, up, down, left, right, etc.) is referenced with the board or enclosure in the orientation shown in the illustrations in this manual.

## General Applications

- 1 The power supply must be installed within the protected area.
- 2 Connections to the SYS FLT, AC FLT, and FAI inputs shall be completed within the same room, not exceeding a length of 3 m.
- 3 Do not connect equipment to an AC power source that is controlled by a switch.
- 4 The power supplies shall be mounted in a UL Listed enclosure.
- 5 Trouble contacts shall be monitored by a listed alarm system.

The following sections cover specific requirements based on application:

### *UL1076, Proprietary Burglar Alarm Applications*

- The Securitron tamper switch must be employed to monitor the power supply.
- To achieve 4 hours of standby at full load current, 80 Ah min. battery capacity is required for the AQL102 or AQL104. To achieve 4 hours of standby at full load current, 40Ah min. battery capacity is required for the AQL4 and AQL6.

### *S319, Access Control Applications*

- The tamper switch must be employed to monitor the power supply.

### *For UL Compliance*

- Any locking device shall be configured for fail safe operation upon occurrence of an alarm as shown in Activation with a Normally Closed Relay Contact (see page 3), FAI Input Usage.

# FAI Usage

The Fire Alarm Interface (FAI) is used to unlock doors during a fire alarm condition. The FAI input will accept various activation methods and must be wired as shown below.

	<h3>Activation with a Normally <u>Open</u> Relay Contact</h3> <p>FAI Activates when the NO contact CLOSES. FAI Deactivates when the NO contact OPENS.</p>
	<h3>Activation with a Normally <u>Closed</u> Relay Contact</h3> <p>FAI Activates when the NC contact OPENS. FAI Deactivates when the NC contact CLOSES.</p> <p>NOTE: FAI with a NC contact cannot be tested by removing the terminal strip, as this will remove the jumper wires from V+ and V- as well. To test, remove one wire going to the NC Contact.</p>
	<h3>Activation with a Voltage Input</h3> <p>FAI Activates when voltage is APPLIED in the correct polarity. FAI Deactivates when voltage is REMOVED.</p>
	<h3>Latching the FAI Input</h3> <p>Latching of the FAI Input is achieved by placing a NC contact across the two 'L' terminals. The FAI may be activated by any of the methods listed. FAI Deactivates when the input is deactivated AND the NC Latching contact is momentarily OPENED.</p> <p><i>Example — NO Contact activation with latching</i></p> <p>FAI Activates when the NO contact CLOSES. FAI Deactivates when the NO contact OPENS AND the NC contact momentarily OPENS.</p>
	<h3>FAI Activation with a Normally Open Relay Contact and AQL AC Fault Lock Override</h3> <p>FAI Activates either, when the Fire Alarm NO contact CLOSES, or when the AC Fault NC contact CLOSES. FAI Deactivates either, when the Fire Alarm NO contact OPENS, or when the AQL AC Fault NC contact OPENS.</p>

# Tamper Switch Wiring

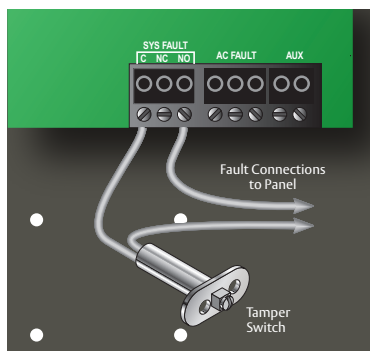

Securiton AQL DC systems with an enclosure may include a normally closed tamper switch for monitoring by the host panel.

The tamper switch may be series connected into the System Fault relay in the AQL supply as shown in the illustration.

Any UL1076 installation must use the tamper switch to indicate the opening or removal of the front door of the enclosure.

# AQL4, AQL6, AQL102/104 Power Supply Boards



## Specifications

### Certifications

- UL 294 Listed
- UL 603 Listed
- UL 1076 Listed
- ULC-S318 Listed
- ULC-S319 Listed
- CE Certified
- CSA C22.2 #107.1
- RoHS Compliant

### Electrical

- Up to 91% efficiency

### Environmental

- Operating Temperature: 32° to 120°F [0° to 49°C]

		AQL4	AQL6	AQL102	AQL104
<b>AC Input</b>	<b>Voltage</b>	120 VAC or 230 VAC at 50 – 60Hz			
	<b>Current</b>	1.8 A max	3.7 A max	3 A	5.7 A
<b>Standby</b>	<b>Current</b>	80 mA	150 mA	110 mA	160 mA
<b>DC Output at 12 V Setting</b> <i>(Auxiliary power-limited output rated at 1.5 A. Total current must not exceed max current)</i>	<b>Voltage</b>	11.3 – 12.0 V	11.2 – 12.0 V	11.3 – 12.0 V	
	<b>Max Current</b>	4 A	6 A	10 A	
	<b>Ripple &amp; Noise</b>	120 mV	120 mV	120 mV	
	<b>Regulation</b>	±2%	±2%	±2%	
	<b>Efficiency</b> <small>(120 VAC 60 Hz In, Full Load, No Batt)</small>	82%	88%	89%	
<b>Auxiliary Output (12 V)</b>	<b>Current</b>	1.5 A max	1.5 A max	1.5 A max	
<b>DC Output at 24 V Setting</b> <i>(Auxiliary power-limited output rated at 1.5 A. Total current must not exceed max current)</i>	<b>Voltage</b>	23.5 – 24.0	23.2 – 24.0		23.4 – 25.0 V
	<b>Max Current</b>	3 A	6 A		10 A
	<b>Ripple &amp; Noise</b>	240 mV	240 mV		240 mV
	<b>Regulation</b>	±2%	±2%		±2%
	<b>Efficiency</b> <small>(120 VAC 60 Hz In, Full Load, No Batt)</small>	83%	85%		91%
<b>Auxiliary Output (24 V)</b>	<b>Current</b>	1.5 A max	1.5 A max		1.5 A max
<b>Battery</b>	<b>Size &amp; Type</b>	4 – 40 AH Lead Acid or Gel Cell	4 – 80 AH Lead Acid or Gel Cell	4 – 80 AH Lead Acid or Gel Cell	4 – 80 AH Lead Acid or Gel Cell
	<b>Charge Current</b>	1 A (±10%) maximum adjustable via DIP switch. 1.0 A high setting, 0.5 A low setting.	1.6 A (±10%) maximum adjustable via DIP switch. 1.6 A high setting, 0.8 A low setting.	1.6 A (±10%) max Charger current is 1.6 A max for high setting, 0.8 A max for low setting.	1.6 A (±10%) max Charger current is 1.6 A max for high setting, 0.8 A max for low setting.
	<b>Low battery disconnect to prevent deep discharge</b>	70% of nominal battery voltage			
<b>Fuse Rating</b>	<b>Battery</b>	ATM 15 A			
<b>BTU Output</b>	<b>BTU/Hr</b>	34 – 41	44 – 62	55	92
<b>Fault Setpoints</b>	<b>Low AC</b>	95 V (±6%)			
	<b>Output Voltage</b>	±10% of nominal			
<b>Fault Relay Contacts</b>	<b>AC FLT</b>	1 A at 24 VDC			
	<b>SYS FLT</b>	1 A at 24 VDC			
<b>Board Size</b>		6"L x 4"W x 2.5"H [152.4mm x 101.6mm x 63.5mm]	8.25"L x 5.5"W x 2.5"H [209.55mm x 139.7mm x 63.5mm]	8.25"L x 5.5"W x 2.5"H [209.55mm x 139.7mm x 63.5mm]	8.25"L x 5.5"W x 2.5"H [209.55mm x 139.7mm x 63.5mm]
<b>Board Weight</b>		.75 lbs	1.0 lbs	1.5 lbs	1.5 lbs
<b>Enclosure Size</b>	<b>E1</b>	14"H x 12"W x 4.5"D [355.6mm x 304.8mm x 114.3mm]			
	<b>E2</b>	20"H x 16"W x 4.5"D [508mm x 406.4mm x 114.3mm]			
<b>Enclosure Weight</b>	<b>E1</b>	14 lbs			
	<b>E2</b>	17 lbs			

## Mounting Power Boards to the Enclosure

Mounting a Securitron Intelligent Power Board to an enclosure via the four snap-in standoffs supplied.

- 1 Locate the appropriate mounting holes in the enclosure and snap the standoffs into the holes.
- 2 Align the board mounting holes with the standoffs (be sure the PC board is properly oriented) and snap the board onto the standoffs.



Intelligent Power Supply Board

## Mounting an Enclosure to a Wall

Use the following procedure when mounting a wall-mount enclosure.

- 1 (Optional) Remove the enclosure's cover.
- 2 Locate the top keyhole mounting holes in the back of the enclosure.
- 3 Mark and pre-drill the locations for the keyholes in the mounting surface.
- 4 Partially install two fasteners appropriate for the surface on which the enclosure is being installed. Leave the heads of the fasteners approximately 1/4" out from the surface. Minimum fastener size should be #10 or larger.
- 5 Hang the enclosure on the two fasteners and mark the locations of the remaining mounting holes.
- 6 Remove the enclosure and pre-drill the locations for the remaining mounting holes.
- 7 Re-hang the enclosure on the top mounting fasteners, start the remaining fasteners and tighten all fasteners.
- 8 Reinstall the enclosure's cover, if removed in Step 1.

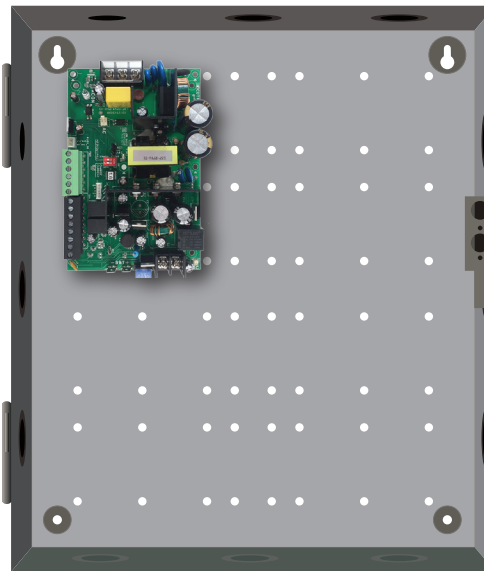

AQL4

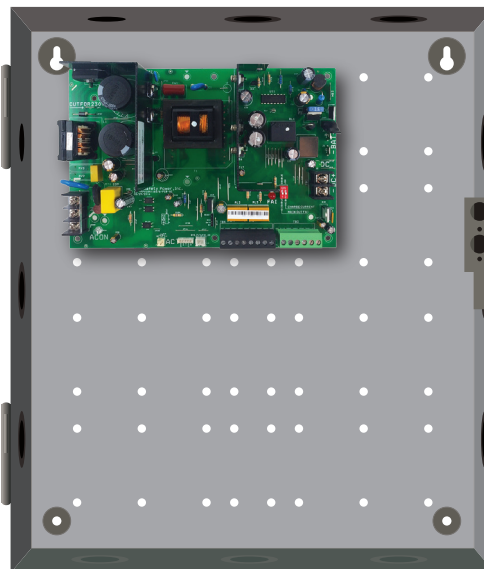

AQL6, 102, 104



**WARNING:** It is the installer's responsibility to determine the appropriate fastening system for use with the surface the enclosure is being mounted to.

For UL1076 applications, after installation is complete, the installer must install the two supplied 1" long screws to the edge of the enclosure's cover for additional security.

# Typical Installation & Wire Routing

*Actual configuration and wire routing will vary based on the components installed in your system.*

The following guidelines should be followed for installation:

- Class 2 Power limited wiring must be separated from nonpower limited wiring by a minimum of 1/4" and must use separate knockouts.
- Any wiring passing through knockouts in the bottom or top surfaces of the enclosure must be enclosed in rigid or flexible metal conduit.
- **Canadian Installations** — For permanently connected equipment, a readily accessible disconnect device shall be incorporated external to the equipment (not shown). Output circuits not connected to removable terminal strips shall also utilize a readily accessible disconnect device.

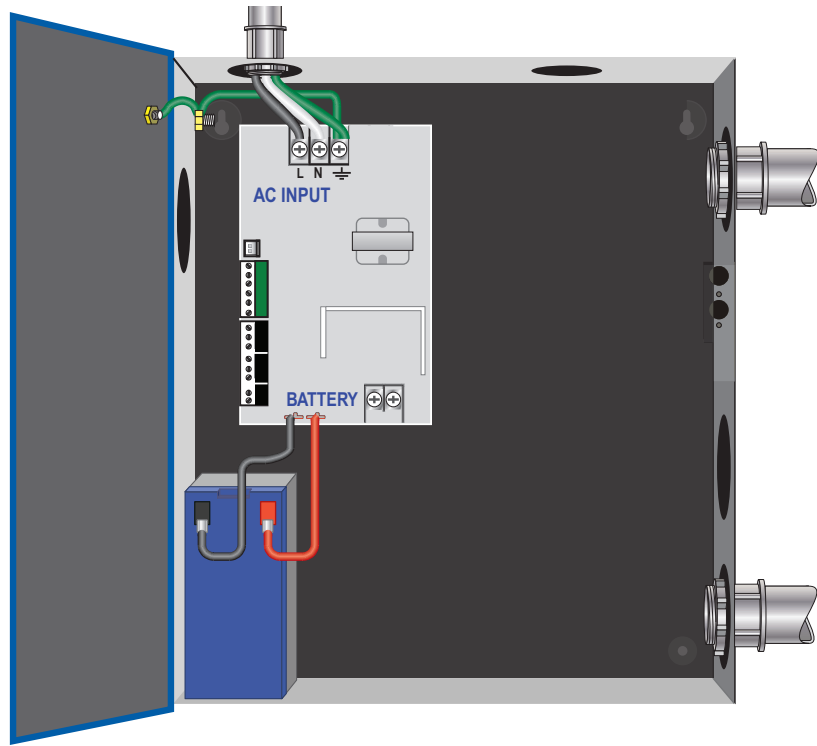

AQL4

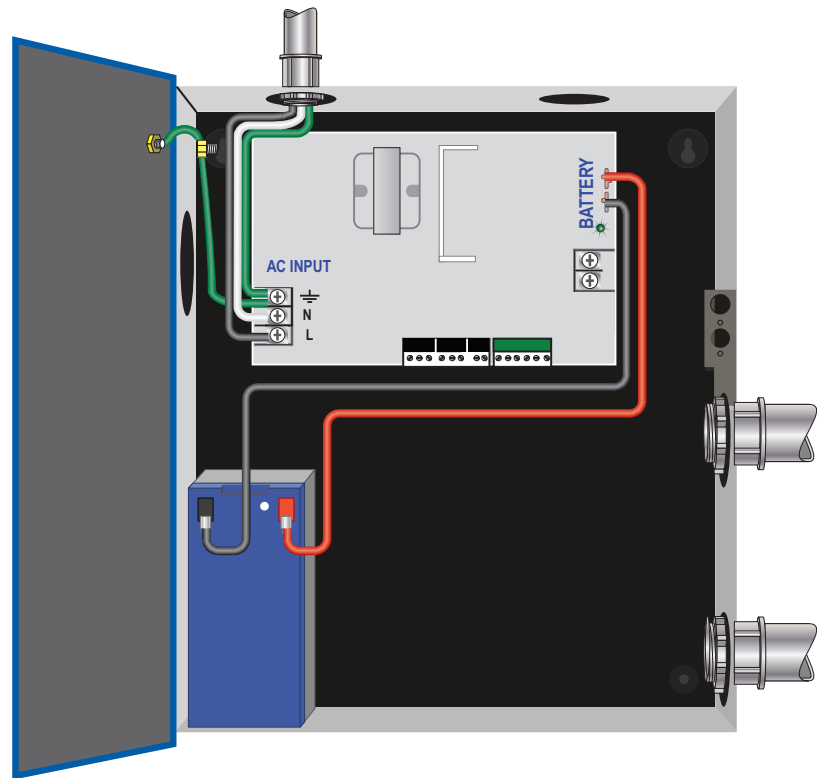

AQL6, 102, 104 (Typical installation)

# AQL4 Power Supply Overview

- 1 AC Input Voltage Selection** — Leave INTACT for 120 V input. CUT for 230 V input.

 **WARNING:** Failure to cut this jumper when using the AQL with a 230 VAC input will result in damage to the system.

- 2 AC Input** — The primary AC connection. Cut Jp1 for 230 VAC input.

- 3 AC On LED (GREEN)** — Indicates a valid AC input voltage is present. Missing AC is indicated by this LED extinguishing.

 **WARNING:** Always confirm the absence of AC power with a meter before servicing to prevent electric shock.

- 4 Voltage Selection Jumper** — Selects the output voltage between 12 V and 24 VDC.

 **WARNING:** Remove AC input power before changing the voltage select switch to avoid damaging the power supply or connected equipment.

- 5 FAI LED (RED)** — Indicates activation of the Fire Alarm Input.

- 6 FlexIO Connector** — Supplies FAI status to any accessory boards. Receives fault signal from accessory boards.

- 7 FAI & Charge Current Configuration Switches**

<b>SWITCH 1 — FAI Selection</b>
<b>OFF</b> = Constant Output
<b>ON</b> = Output switches on FAI
<b>SWITCH 2 — Charge Current</b>
<b>OFF</b> = High Charge Current
<b>ON</b> = Low Charge Current

- 8 System Fault Contact** — Contact labeling is adjacent to the terminals and shown in the unpowered (FAULT) condition.

- 9 AC Fault Contact** — Contact labeling is adjacent to the terminals and shown in the unpowered (FAULT) condition. AC fault is indicated on a missing AC Input voltage.

- 10 Auxiliary Voltage** — A fixed Class 2 DC output.

- 11 FAI Input** — The input from the FACP. Can be wired to accept a NO, NC, Open Collector, or Voltage input.

- 12 Battery Terminal Connection** — For the optional battery backup. Battery set voltage must match the DC output voltage setting.

- 13 Main Output** — Output of the power supply. The output can either be constant or switched based on the configuration setting of Switch 1.

 **WARNING:** Remove AC input power before changing the voltage select switch to avoid damaging the power supply or connected equipment.

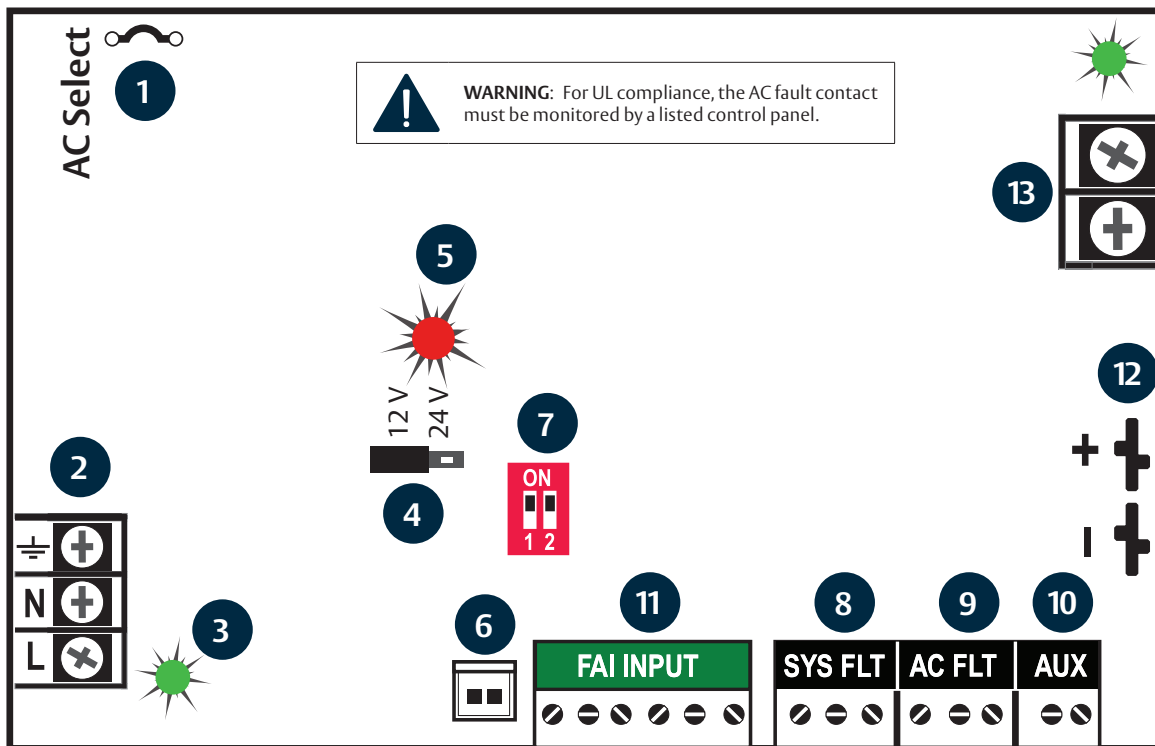

# AQL6 Power Supply Overview

- 1 AC Input Voltage Selection** — Leave INTACT for 120 V input. CUT for 230 V input.

 **WARNING:** Failure to cut this jumper when using the AQL with a 230 VAC input will result in damage to the system.

- 2 AC Input** — The primary AC connection. Cut JP1 for 230 VAC input.

- 3 AC On LED (GREEN)** — Indicates a valid AC input voltage is present. Missing AC is indicated by this LED extinguishing.

 **WARNING:** Always confirm the absence of AC power with a meter before servicing to prevent electric shock.

- 4 FAI LED (RED)** — Indicates activation of the Fire Alarm Input.

- 5 FAI & Charge Current Configuration Switches**

<b>SWITCH 1 — FAI Selection</b>
OFF = Constant Output
ON = Output switches on FAI
<b>SWITCH 2 — Charge Current</b>
OFF = High Charge Current
ON = Low Charge Current

- 6 FlexIO Connector** — Supplies FAI status to any accessory boards. Receives fault signal from accessory boards.

- 7 System Fault Contact** — Contact labeling is adjacent to the terminals and shown in the unpowered (FAULT) condition.

- 8 AC Fault Contact** — Contact labeling is adjacent to the terminals and shown in the unpowered (FAULT) condition. AC fault is indicated on a missing AC Input voltage.

- 9 Auxiliary Voltage** — A fixed Class 2 DC output.

- 10 FAI Input** — The input from the FACP. Can be wired to accept a NO, NC, Open Collector, or Voltage input.

- 11 Main Output** — Output of the power supply. The output can either be constant or switched based on the configuration setting of Switch 1.

 **WARNING:** Remove AC input power before changing the voltage select switch to avoid damaging the power supply or connected equipment.

- 12 Battery Terminal Connection** — For the optional battery backup. Battery set voltage must match the DC output voltage setting.

- 13 Voltage Selection Jumper** — Selects the output voltage between 12 V and 24 VDC.

 **WARNING:** Remove AC input power before changing the voltage select switch to avoid damaging the power supply or connected equipment.

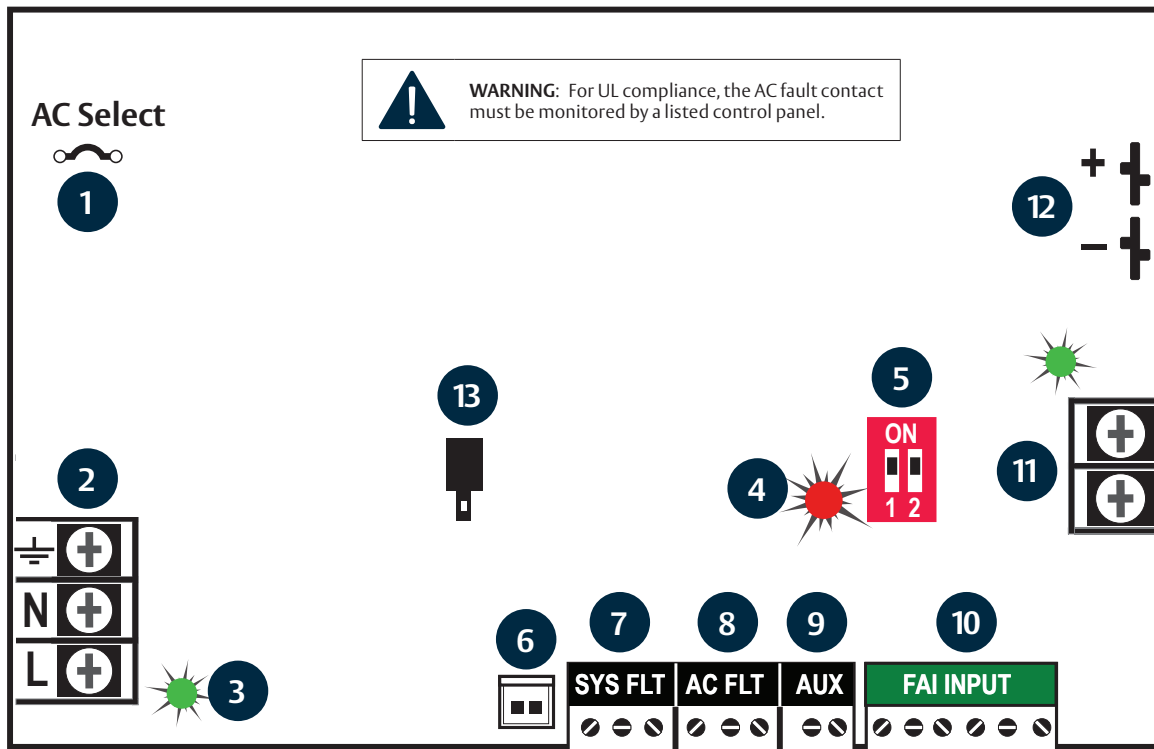

# AQL102/104 Power Supply Overview

- 1 AC Input Voltage Selection** — Leave INTACT for 120 V input. CUT for 230 V input.

 **WARNING:** Failure to cut this jumper when using the AQL with a 230 VAC input will result in damage to the system.

- 2 AC Input** — The primary AC connection. Cut JP1 for 230 VAC input.

- 3 AC On LED (GREEN)** — Indicates a valid AC input voltage is present. Missing AC is indicated by this LED extinguishing.

 **WARNING:** Always confirm the absence of AC power with a meter before servicing to prevent electric shock.

- 4 FAI LED (RED)** — Indicates activation of the Fire Alarm Input.

- 5 FAI & Charge Current Configuration Switches**

**SWITCH 1 — FAI Selection**  
**OFF** = Constant Output  
**ON** = Output switches on FAI

**SWITCH 2 — Charge Current**  
**OFF** = High Charge Current  
**ON** = Low Charge Current

- 6 FlexIO Connector** — Supplies FAI status to any accessory boards. Receives fault signal from accessory boards.

- 7 System Fault Contact** — Contact labeling is adjacent to the terminals and shown in the unpowered (FAULT) condition.

- 8 AC Fault Contact** — Contact labeling is adjacent to the terminals and shown in the unpowered (FAULT) condition. AC fault is indicated on a missing AC Input voltage.

- 9 Auxiliary Voltage** — A fixed Class 2 DC output.

- 10 FAI Input** — The input from the FACP. Can be wired to accept a NO, NC, Open Collector, or Voltage input.

- 11 Main Output** — Output of the power supply. The output can either be constant or switched based on the configuration setting of Switch 1. The DC ON LED will light: GREEN 12 V | BLUE 24 V.

- 12 Battery Terminal Connection** — For the optional battery backup. Battery set voltage must match the DC output voltage setting.  
 Power Supply Fixed Voltage:  
 • AQL102: 12 V – AQL102  
 • AQL104: 24 V – AQL104

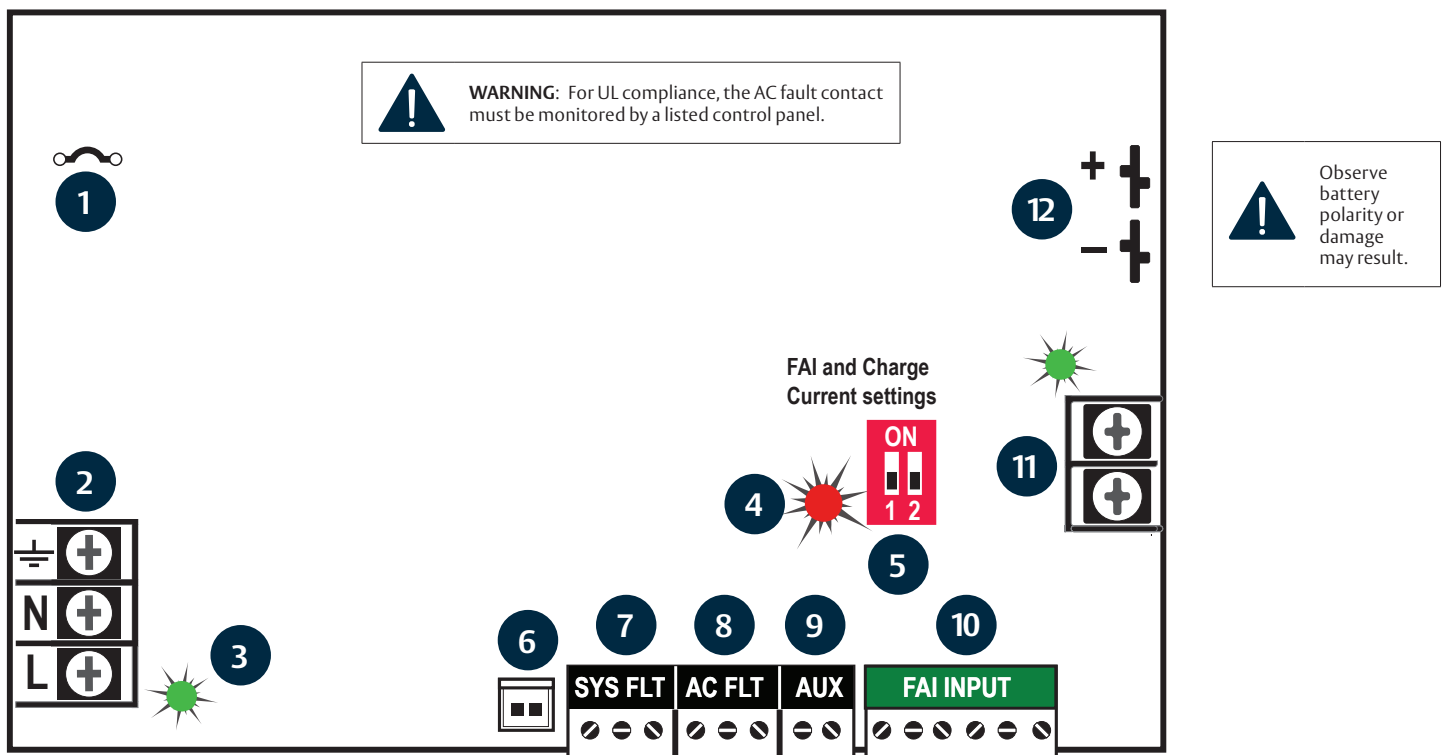

# D8/D8P Power Distribution Module

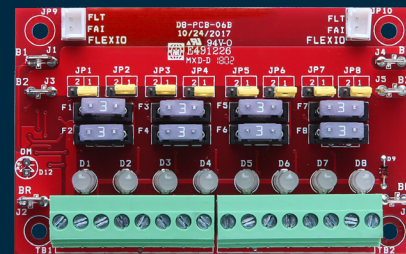

## Specifications

### Certifications

- UL 294 Listed
- UL 603 Listed
- UL 1076 Listed
- ULC-S318 Listed
- ULC-S319 Listed
- CSA C22.2 #205
- RoHS Compliant
- CSFM Approved

### Electrical

- 8 continuous outputs
- Input
  - Voltage: 5-24 VDC nominal
  - Current: 12 A maximum
  - Standby Current: 65 mA
- Output
  - Voltage: same as input
  - D8 Current: 3 A resistive
  - D8P Current: 2.5 A resistive
- Fuse
  - 3A: ATM automotive style (D8)

### Shipping Weight

- .25 lbs

### Dimensions

- 4" x 2.5" x 1"  
[101.6mm x 63.5mm x 25.4mm]

## Overview

- FlexIO Connectors** — These connectors pass the FlexIO buss through the D8 to other accessory boards in the system.
- B1 Connectors (J1 & J4)** — These fastons are for connection to the B1 voltage buss in the system. The voltage on the B1 buss comes from the main output of an AQL power supply. This voltage will be directed to any outputs whose Output Selection Jumper is set in the B1 position.
- B2 Connectors (J3 & J5)** — These fastons are for connection to the B2 voltage buss in the system. The voltage on the B2 buss comes from the main output of an AQL power supply in a dual voltage system. This voltage will be directed to any outputs whose Output Selection Jumper is set in the B2 position. If the D8 is being used in a single voltage system, these fastons can be left unused.
- BR Connectors (J2 & J6)** — The DC Common buss in the system. All boards in the system must have their BR fastons wired together for proper operation.
- Output Selection Jumpers (JP1–JP8)** — These jumpers select which voltage buss input is selected for the output. Jumper numbers correspond with the zone number (e.g. JP1 is the jumper for OUT1). Possible settings are as follows:
  - Position 2 (LEFT) — B2 Buss
  - Position 1 (RIGHT) — B1 Buss
  - Removed — Disable Output
- Output Fuses (F1–F8)** — When using the fused version of the D8, these are the fuses for each zone output. Fuse numbers correspond with the zone number (e.g. F1 is the fuse for OUT1). When using the PTC version of the D8, the fuse will be replaced with a soldered-in PTC.
- Output LEDs (D1–D8) (Dual Color – GREEN/BLUE)** — These LEDs indicate the availability of voltage on a zone's output. When voltage is available on the output terminals, the LED is lit. GREEN 12 VDC BLUE 24 VDC. LED numbers correspond with the zone number (e.g. D1 is the LED for OUT1).
- Zone Outputs (Out1–Out8)** — These are the zone output terminal strips. These terminal strips are removable and accept wire sizes from AWG 14 – AWG 22. The terminals are labeled on the PC board underneath the terminal strip.

**WARNING:** When powering magnetic loads such as maglocks, door strikes, solenoids, etc, each of these loads must have a reverse protection diode either built-in or external to the device.

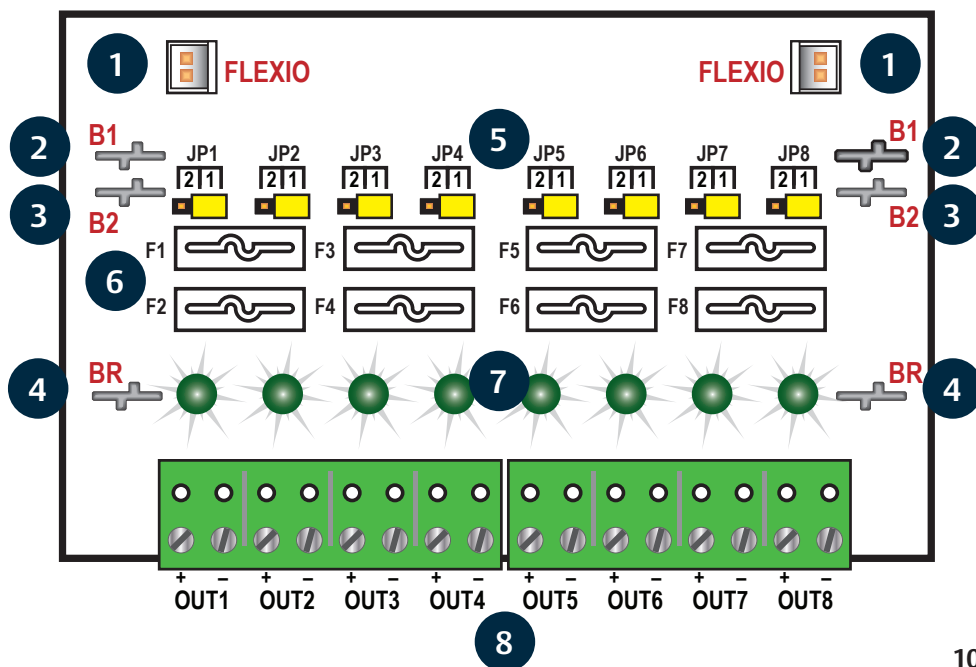

# R8 Relay Module

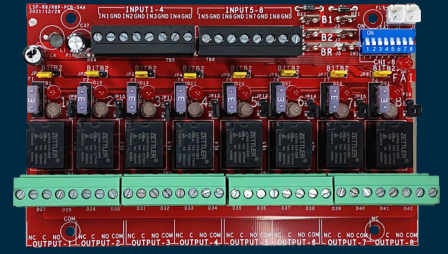

## Specifications

### Certifications

- UL 294 Listed
- UL 603 Listed
- UL 1076 Listed
- ULC-S318 Listed
- ULC-S319 Listed
- CSA C22.2 #205
- RoHS Compliant
- CSFM Approved

### Electrical

- Input
  - Voltage: 12 or 24 VDC nominal  $\pm 15\%$
  - Current: 12 A maximum
  - Standby Current: .6 A at 12 V and .3 A at 24 V (all relays energized)
- Zone Input
  - Zone Count: 8
  - Max Current: 10 mA
- Zone Output
  - Zone Count: 8
  - Voltage: same as input
  - R8 Current: 3.0 A resistive

- R8P Current: 2.5 A resistive (Class 2 power LTD)
- Fuse
  - 3 A: ATM automotive style (R8)

### Environmental

- Operating Temperature: 32° to 120°F [0° to 49°C]

### Shipping Weight

- 1 lb

### Dimensions

- 6" x 4" x 2.5" [152.4mm x 101.6mm x 63.5mm]

## Overview

- FlexIO Connectors** — These connectors pass the FAI signal to the R8 board and pass the FlexIO buss on to other accessory boards in the system.
- B1, B2, and BR Connectors** — These connectors are the voltage inputs for the R8 board. BR is the DC Common buss in the system. B1 is the positive voltage input for the first power supply. In dual voltage systems, B2 is the input for the second power supply.
- Zone Inputs (IN1–IN8)** — These are the zone input terminal strips. These terminal strips are removable and accept wire sizes from AWG 14–AWG 22. The terminals are labeled on the PC board near the terminal strip (see page 12).
  - When using a normally open relay contact input, the contact is connected across the IN and GND terminals.
  - When using an open collector (transistor) input, the open collector is connected to the IN terminal. Note that the input source must be common grounded with the R8 board's power source.
- Voltage Selection Jumpers (YELLOW)** — These jumpers select the power input to be used for each output. For single voltage systems, this jumper should stay in the B1 position. This jumper should be removed on any zones where a dry contact output is needed.
- Relay State LEDs (RED)** — These LEDs indicate the state of the output relay. The LED will be lit when the relay is active and extinguished when the relay is not active.

- Output Voltage LEDs (Dual Color – BLUE/GREEN)** — These LEDs indicate the voltage of the zone's output.
  - BLUE The output is set to 24 V
  - GREEN The output is set to 12 V
  - OFF Blown fuse, no fuse, or dry contact output selected
- Zone Outputs (01–08)** — These are the zone output terminal strips. These terminal strips are removable and accept wire sizes from AWG 14 – AWG 22. The terminals are labeled on the PC board near the terminal strip. See the Output Wiring section for more information. C, NC, and NO are the relay output. Details next page.

- Dry Output Selection (BLACK)** — When a dry contact output is needed, this jumper must be removed in addition to the yellow jumper for the zone. The output diodes must also be cut for the zone.



**WARNING:** When a dry contact output is needed, the Yellow and Black jumpers must be removed and the output diodes must be cut.

- Output Fuses (F1–F8)** — These are the fuses for each zone output. Fuse numbers correspond with the zone number (e.g. F1 is the fuse for OUTPUT1). Fuses are not in the circuit when the zone is being used as a relay contact output.

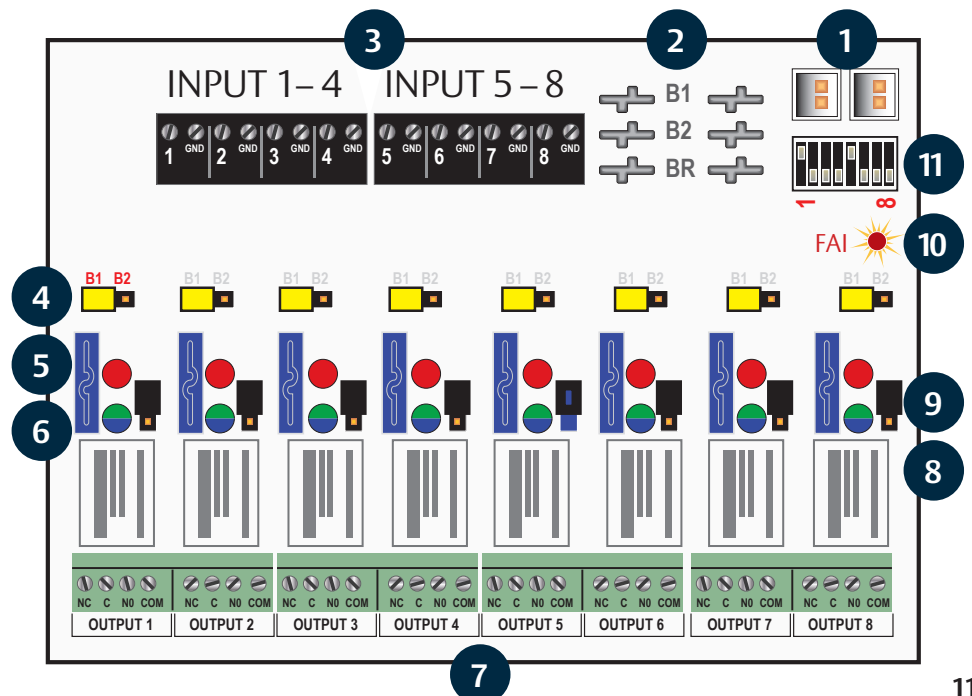

**10 FAI LED (RED)** — This LED indicates that the R8 has received an FAI signal from the AQL power supply through the FlexIO connector. When lit, any zones selected to respond to FAI will unlock.

**11 FAI Selection Switches (SW1)** — These switches select FAI for each output. Switch 1 is for Zone 1, Switch 2 for Zone 2, etc. When the switch is OFF, the zone will unlock when an FAI is received.



**WARNING:** When powering magnetic loads such as maglocks, door strikes, solenoids, etc, each of these loads must have a reverse protection diode either built-in or external to the device.

## Power Control Dry Contact Output

The outputs of the R8 have built-in reverse protection diodes. If a delay in lock release is present or if the zone is being used as a dry contact output, the diode from that zone may be removed from the circuit as shown below.



**WARNING:** Only remove the diodes from outputs requiring their removal.

## Diode Removal

The diodes on the R8 are on the top side of the board between the output terminals and the edge of the board. To remove the diode from the output circuit, simply cut the exposed diode lead for the desired output zone — leave the diode body soldered to the PCB.

## Input Wiring

Each input on the R8 has an “IN” terminal and a “GND” terminal.

- When using a NO relay contact to activate the input, the contact is placed across these terminals.
- To use a DC ground or an open collector (transistor) as an input, connect the ground/open collector to the “IN” terminal to activate the input. Note that the input source must be common grounded with the R8 board’s power source.

## Output Wiring

Each output on the R8 has “NC”, “C”, “NO”, and “COM” terminals.

- When set for a dry contact output, the C, NC, and NO terminals may be used as any relay would. C to NC will have a connection when the red LED for the zone is not lit. C to NO will have a connection when the red LED is lit.



**WARNING:** To set the output as a dry contact, the yellow and black jumpers for the zone must be removed and the output diodes must be cut.

- When set for a voltage output, the terminal use is as follows:
  - **COM** — This is the Negative DC Common for the device being powered.
  - **C** — This terminal always has positive voltage, regardless of the relay state. This terminal may be used to power auxiliary devices such as REX or readers.
  - **NC** — This output has positive voltage when the relay is NOT ACTIVE. This terminal is used for FAIL SAFE locks.
  - **NO** — This output has positive voltage when the relay is ACTIVE. This terminal is used for FAIL SECURE locks.



**WARNING:** Other Securitron Power Boards (not part of AQL series) use C as a negative DC common.

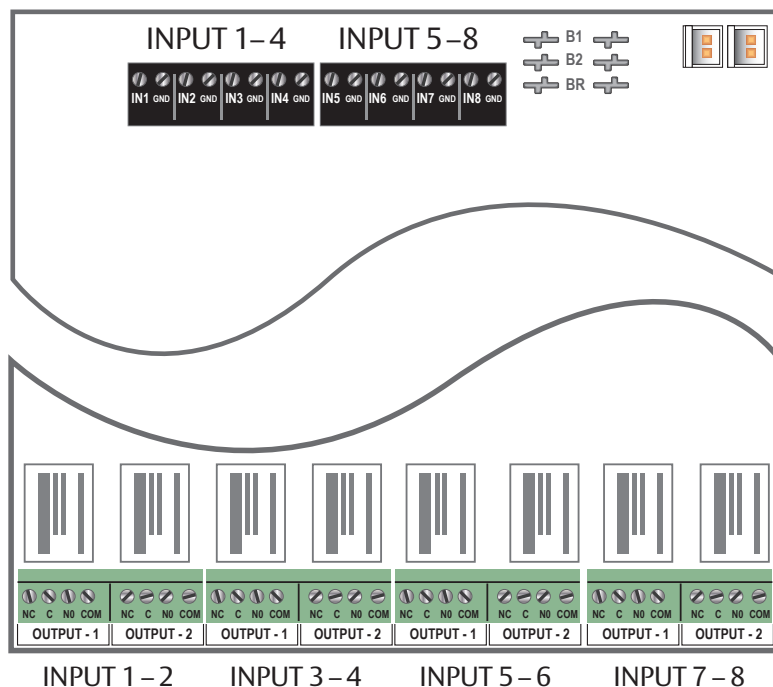

Input Wiring

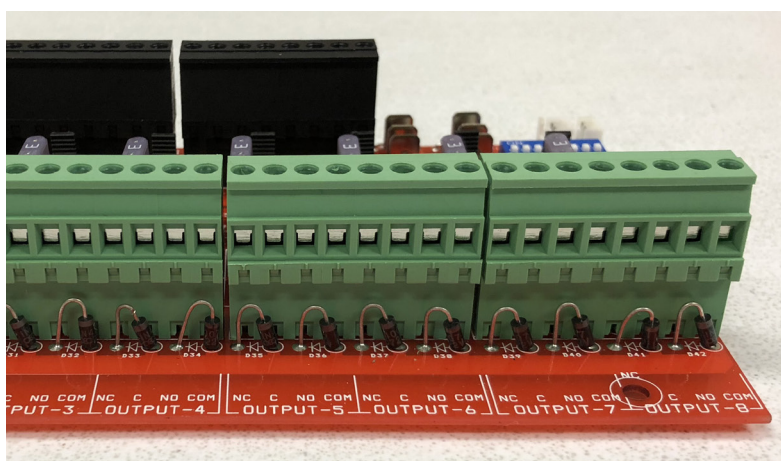

Output Wiring

# B100 Secondary Voltage Module

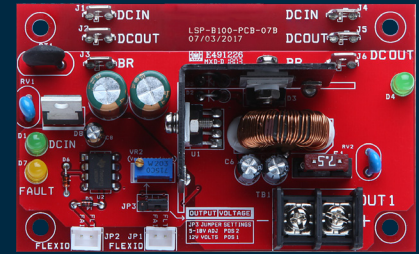

## Specifications

### Certifications

- UL 294 Listed
- UL 603 Listed
- UL 1076 Listed
- ULC-S318 Listed
- ULC-S319 Listed
- CSA C22.2 #205
- RoHS Compliant

### Electrical

- Input
  - Voltage: 8-25 V (Must be at least 3 V above output voltage setting)
  - Current: 3.5 A maximum
  - Standby Current: 35 mA
- Output
  - Voltage: 4.7-23 V
  - Current: 4 A maximum (Class 2 power limited)
- Fuse
  - 7.5 A ATM automotive style

### Shipping Weight

- .2 lbs

### Dimensions

- 4" x 2.5" x 1.75"  
[101.6mm x 63.5mm x 44.5mm]

## Description

The Securitron B100 provides an additional voltage in a Securitron AQL power system. This voltage can either be accessed directly via the B100's terminals or through other AQL Accessory Boards. The B100's input

is typically supplied by the B1 buss in the system, allowing the AQL's battery set to back up the B100's output voltage without the need for a second battery set. Output settings for the B100 include a fixed 12 V

setting and an adjustable setting of 5 to 18 V. Multiple B100s can be added to a system for virtually unlimited voltage combinations.

# Overview

- DC IN Connectors (J1 & J4)** — These fastons are the input to the B100. Either faston may be used as the input. Two connections are provided to allow this voltage to pass through to other accessory boards in the system. This input voltage must always be at least 3 volts above the output voltage setting for the B100 to maintain its output.
- DC OUT Connectors (J2 & J5)** — These fastons are the output of the B100 for connection to other accessories in the system. This output may be considered as an equivalent to the main output of an AQL power supply. Either or both DC OUT fastons may be used in the system.

 **WARNING:** Ensure there are no other voltage sources connected to the buss before powering the system or damage WILL occur.

- BR Connectors (J3 & J6)** — The DC Common buss in the system. All boards in the system must have their BR fastons wired together for proper operation.
- DC IN LED (D1) (BLUE/GREEN)** — This LED indicates the availability of voltage on the DC IN Buss. When voltage is available on the buss, the LED is lit. This LED is bi-color and indicates the input voltage as follows: GREEN – 12 V Input | BLUE – 24 V Input.

 **WARNING:** LED colors are range based. Voltage Less than 13 V will show Green. Voltage above 20V will show Blue. Voltage between 13 and 20 may show either voltage or a combination Green & Blue. Always verify voltage with a voltmeter.

- FAULT LED (D7) (YELLOW)** — This LED lights when the B100 detects a fault condition. This fault condition also transmits to the AQL power supply. Fault conditions detected include ruptured output fuse, no output, output overload, or output voltage out of regulation.

- FlexIO Connectors (JP1 & JP2)** — These connectors allow the fault status of the B100 to be transmitted to the AQL power supply and pass the FlexIO buss on to other accessory boards in the system.
- Output Voltage Selection (JP3 & VR1)** — This jumper selects the output voltage for the B100 and the potentiometer sets the output voltage when in the adjustable range. In adjustable range, voltage may be set from 5 to 18 VDC. *Possible jumper settings are as follows:*
  - 12 V Out JP3 Position 1
  - Adjustable Output JP3 Position 2

 **WARNING:** The VR1 potentiometer will have no effect unless the jumper is set for the adjustable range.

The input must be at least 3 V above the output voltage setting or the B100 will display a fault condition. It may be helpful to temporarily set the input power supply to 24 V (Remove load devices first) before setting the B100 output voltage.

- DC Output** — This is the output terminal strip. This terminal strip is nonremovable and accepts wire sizes from AWG 12 – AWG 22. The terminals are labeled on the PC board by the terminal strip.
- Output Fuse (F1)** — This fuse protects the DC Output terminals. It does not protect the DC OUT faston.
- DC OUT LED (D4) (GREEN)** — This LED indicates the availability of voltage on the DC OUT Buss. When voltage is available on the buss, the LED is lit.

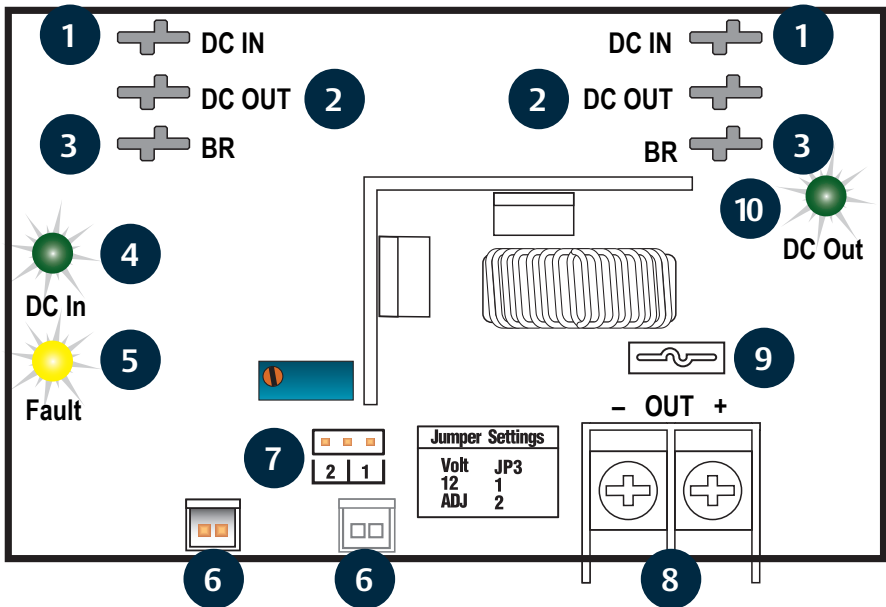

## Current Loading

Power drawn from the B100 subtracts from the power available from the AQL supplying the B100. The most accurate way to determine the draw from the AQL is to calculate the actual power draw and factor in the efficiency of the B100.

$$PI = PO * 1.15$$

Where:

- **PI** = Input power of the B100
- **PO** = Output power draw on the B100

MAX POWER AVAILABLE	12V	24V
AQL4	48 W	72 W
AQL6	72 W	144 W
AQL102	120 W	—
AQL104	240W	—

## Current Load Examples

**Example 1** What size AQL power supply do you need to create a dual voltage power supply system providing 24 V at 2 A and 12 V at 2 A?

- 1 Determine current load:  $12\text{ V} \times 2\text{ A} = 24\text{ W} \times 1.15 = 27\text{ W} \mid 24\text{ V} \times 2\text{ A} = 48\text{ W}$
- 2  $27\text{ W} + 48\text{ W} = 75\text{ W}$  current load
- 3 Find AQL power supply rating: 144 W for AQL6  $\mid$  240 W for AQL104
- 4 Use AQL6 or AQL104 to meet the system's power needs.

**Example 2** An AQL4 is powering a B100. The B100 is set for an output of 12 V and has 3 A total load connected. How much power is available from the AQL4?

- 1 Determine current load:  $12\text{ V} \times 3\text{ A} = 36\text{ W} \times 1.15 = 41\text{ W}$
- 2 Find AQL power supply rating: 48 W for the AQL4
- 3 Subtract current load from power supply rating:  $48\text{ W} - 41\text{ W} = 7\text{ W}$  available from AQL power supply.

**Example 3** What size AQL power supply do you need to create a dual voltage power supply system providing 24 V at 4 A and 5 V at 2 A?

- 1 Determine current load:  $5\text{ V} \times 2\text{ A} = 10\text{ W} \times 1.15 = 11\text{ W} \mid 24\text{ V} \times 4\text{ A} = 96\text{ W}$
- 2  $11\text{ W} + 96\text{ W} = 107\text{ W}$  current load
- 3 Find AQL power supply rating: 144 W for AQL6
- 4 Use an AQL6 to meet the system's power needs.

## Connecting the B100



Remove all AC and battery power from the AQL system before adding or replacing a B100 board.



Observe polarity of the DC IN and BR Connections or damage to the system could occur.



**WARNING:** The DC IN, DC OUT, and BR terminals run through the board for daisy chaining and each terminal set is interchangeable from a functional standpoint. Either DC IN may be used, either DC OUT may be used or either BR may be used interchangeably.

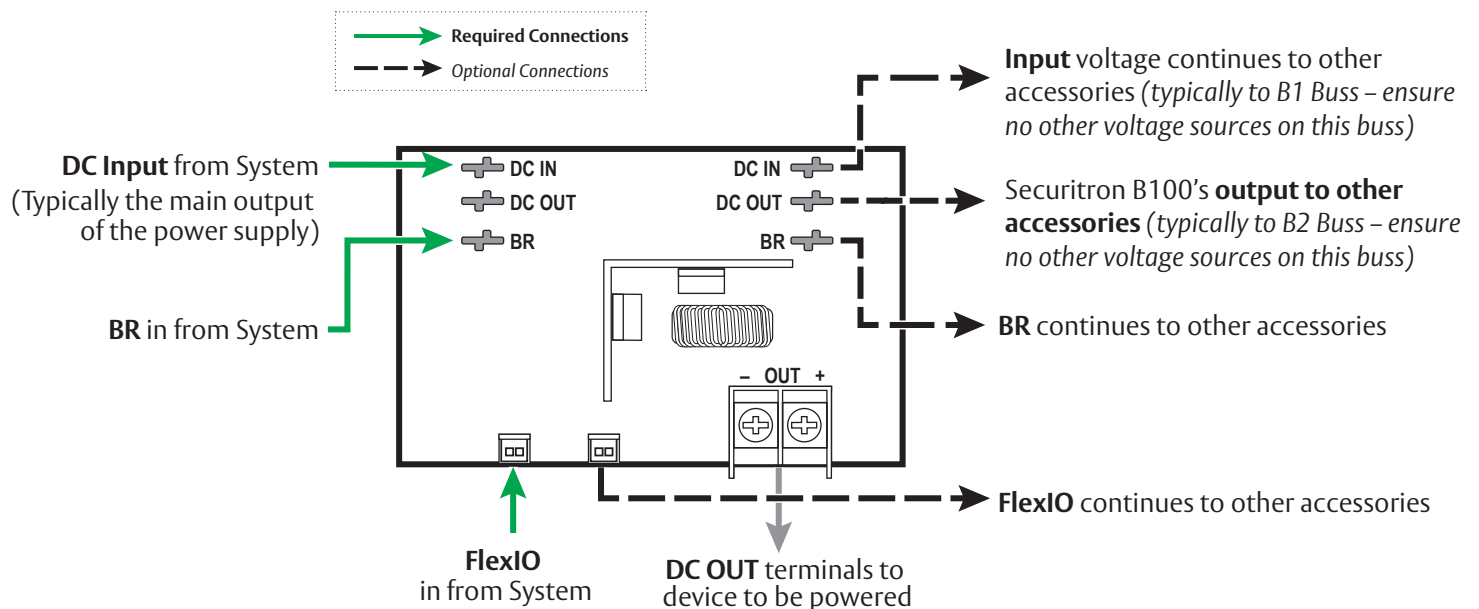

# Application Examples

## Dual Voltage 24 V | 12 V

### Using:

- One (1) AQL Power Supply
- One (1) B100 Secondary Voltage Module

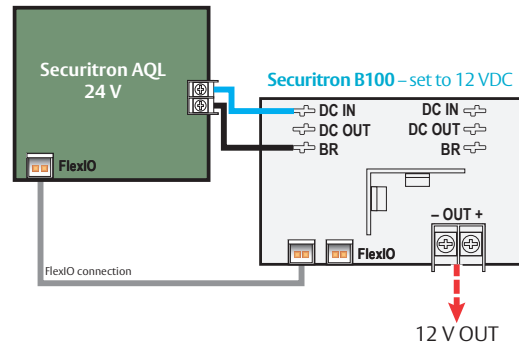

## Dual Voltage 24 V | 12 V

### Using:

- One (1) AQL Power Supply
- One (1) B100 Secondary Voltage Module
- One (1) D8/D8P Power Distribution Module

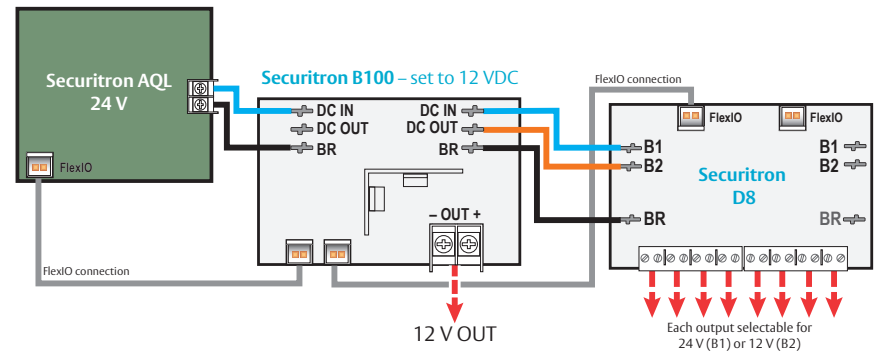

## Multi Voltage 24 V | 12 V | 5 V

### Using:

- One (1) AQL Power Supply
- Two (2) B100 Secondary Voltage Modules

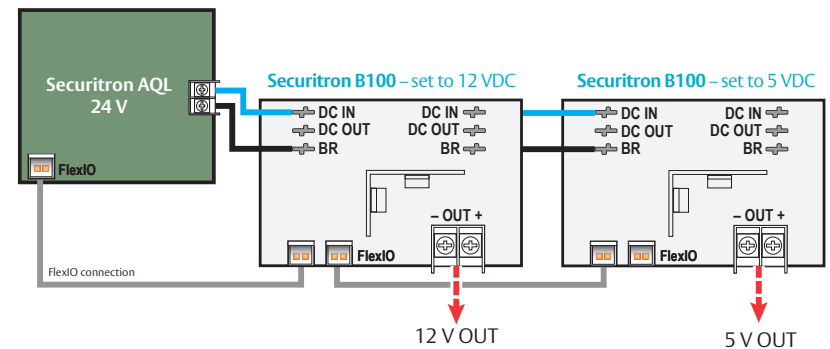

## Multi Voltage 24 V | 12 V | 5 V

### Using:

- One (1) AQL Power Supply
- Two (2) D8 Power Distribution Modules
- Two (2) B100 Secondary Voltage Modules

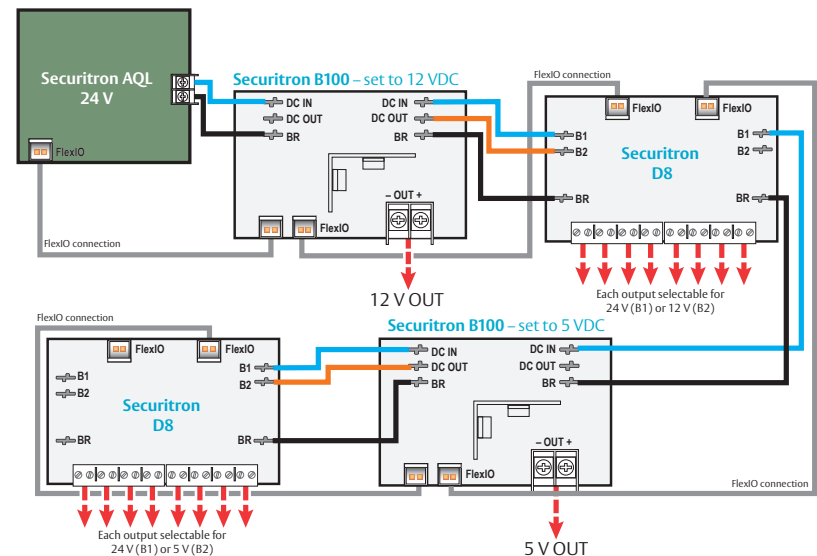

**Warranty** For information on warranty coverage and replacement options, please visit [securitron.com/warranty](http://securitron.com/warranty)