

RECESSED ACCESS DOOR WITH DRYWALL FLANGE

AHA-GYP

INSTALLATION

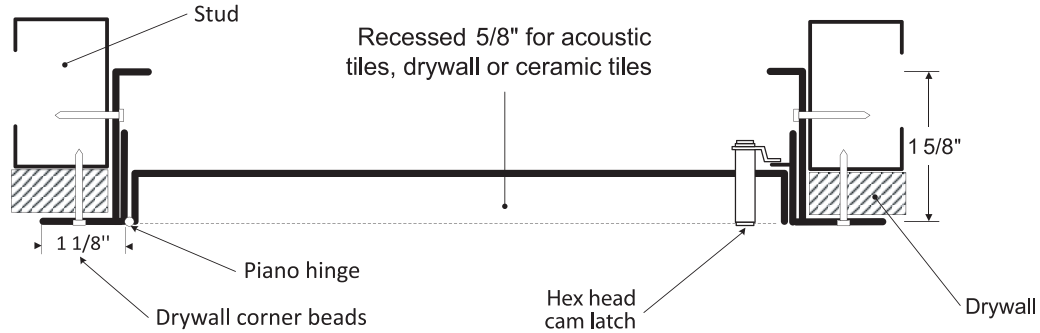

DIMENSIONS AND APPEARANCE

LEED ready: This product contributes to LEED® credits.

DOOR SIZE - W x H INCHES (MM)	NUMBER OF LOCKS	WEIGHT LBS KG	
8 x 8 (203 x 203)	1	3	1.4
12 x 12 (304 x 304)	1	5	2.3
16 x 16 (406 x 406)	1	9	4.1
18 x 18 (457 x 457)	1	11	5
24 x 24 (609 x 609)	1	16	7.3
Rough wall opening is door size + 1/4" or + 6mm			

**ACCESS DOORS  
MADE FAST!**

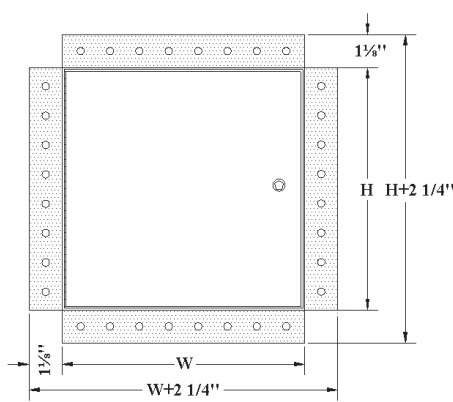

DESCRIPTION AND MATERIAL SPECIFICATION

- Material:** 16 gauge cold rolled steel
- Hinge:** continuous piano hinge
- Lock / latch:** Allen hex head cam latch
- Finish:** high quality white powder coat primer
- Packaging:** individually wrapped, 1 per box
- Recess:** 5/8" standard
- GYP:** drywall corner beads flange

POPULAR OPTIONS:

- Latch:** key operated cylinder cam latch
- Material:** stainless steel 304 #4 (brushed finish)
- Recess:** 1/2" to 3/4" (standard 2" frame)  
13/16" to 1 1/2" (special 3" frame)

PROJECT DATA

PROJECT NAME:	QTY	W	H	OPTIONS
ARCHITECT:				
DEALER:				
CONTRACTOR:				
LOCATION:	SPECIAL INSTRUCTIONS:			
DATE:				
TAGGING INSTRUCTIONS:	SUBMITTAL APPROVAL: (signature or stamp)			